

# Grid Connected Photo Voltaic and Fault Analysis

Ritesh Dash<sup>1</sup>, Kunjan Kumar Mohapatra<sup>2</sup>, Pratik Ranjan Behera<sup>3</sup>, Dr. S.M Ali<sup>4</sup>

School of Electrical Engineering, KIIT, University<sup>1,2,3,4</sup>

**Abstract:** Fault is a common term associated with every type of electrical devices under abnormal condition. PV panel faults include installation faults, fault due to environment and material defect or degradation. All these things mainly depend upon the temperature effect and somehow related to the manufacturing defect. So fault analysis in grid connected solar PV system is a primary task to provide reliability and to avoid risks of safety hazards. We have investigated different types of fault occurring in a solar PV system mainly line to ground fault and line to line fault. These two faults mainly decrease the open circuit fault and increase the current feeding to the grid, which in turn affects the efficiency of the system. A simulation with Matlab is carried out to check the performance of the system under different fault condition.

**Key Words:** Solar cell, MPPT, Reliability

## 1. INTRODUCTION

The demand for electrical energy is increasing day by day. A large portion of the electrical energy is generally obtained from the conventional fuel i.e. by burning the fossile fuel such as coal, petroleum products and natural gasses. The energy obtained from this fossil fuel has no comparison but it produces a lot of pollution by emitting gases such as NO<sub>x</sub>, SO<sub>x</sub>. These pollutions can be avoided by harvesting energy from the sun through PV cell.

However for obtaining the maximum power generally MPPTs are installed in conjunction with solar cell. As in case of power system different types of fault occurs at different condition similarly the solar cell s also suffers from different types of fault. So fault analysis in solar PV arrays is a fundamental task to increase the system reliability, efficiency and safety [2]. If fault becomes become more severe then it may damage the cell module. So in order to avoid any types of risk solar cell must be avoided with some type of protecting device. Solar cell fault may be classified into three groups1) fault inside the cell2) fault in interconnecting device3) fault in the grid. Figure -1 shows a solar panel connected to a solar collector which basically collects the solar power and

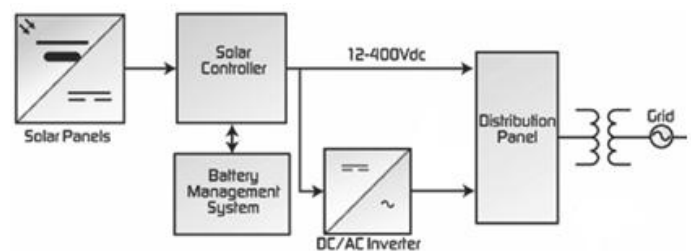

Fig:-1 block diagram of solar PV connected to grid

stores it in the battery. It also connected with an MPPT so as to track the maximum power from the source. Under day light condition it directly feeds to the grid and in the evening battery supply to the grid. DC to AC converter is generally used to connect the PV module to the grid.

## 2. FUNDAMENTALS OF PHOTOVOLTAIC SYSTEM

### 2.1 General aspects of solar cell.

A solar cell is based on the semiconductor photovoltaic volt effect. When a junction between p and n type material is formed, the carriers diffuse from a higher concentration side to a lower concentration side. Soon after crossing the junction, these carriers recombine with the other types of carrier found in majority on the other side. The energy in a photon must exceed the semiconductor band gap energy

$E_g$  in order to get absorbed. If the light on the solar cell is absorbed in the interface, the photon with enough energy can inspire electron from the co-valent bond in the p-type silicon and n-type silicon and hence produce the electron hole pair. The more the electron generate the higher the current.

### 2.2 Stand alone

Photovoltaic systems can be designed to provide DC and/or AC power service, can operate interconnected with or independent of the utility grid, and can be connected with other energy sources and energy storage systems. It is most relevant and successful in remote and rural areas having no access to grid supply.. interactive capacity of such a system is 10Wp-100kWp.

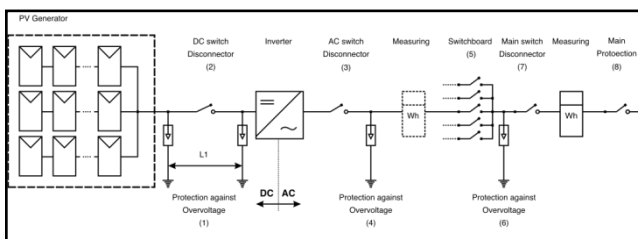

Fig:-2 solar PV systems connected to grid

Figure-2 shows the connection diagram of solar PV system connection to the grid. The DC link is always controlled by the feedback taken from the grid, which also controls the MPPT.. However circuit breaker are provided just before the grid to disconnect the solar cell under faulty condition.

### 2.3 Grid connected

This system is connected to the grid. Generally two way metering system is provided for this. It meets day time requirements of the house owner without any battery backup and surplus power is fed to the grid. During night time the requirement power can be drawn from the grid.

## 3. DIFFERENT TYPES OF FAULT

### 3.1 Panel fault

It is basically a local hot spot. Local hot spot reduces the panel output power. It occurs when a cell in a series string

of cell becomes reverse biased and hence dissipates the power in the form of heat. The heat is regarded as the loss of power. The main cause for hotspot is the partial shading. If it is not prevented as early as possible it may leads to the other cell and hence connection failure may occurs. Bypass diodes are often used to limit the reverse bias voltage across the PV panel and limit the hot spot.

### 3.2 Line-to-Line Fault

A line to line fault is a least common type of fault which occur in a PV system. It occurs due to low resistance connection established between the two points of different potential. In PV system a line-to-line fault is an accidental short circuiting between array of different potential. This type of fault mainly occurs due to 1) failure of insulation of cable 2) short circuit between current carrying conductor 3) line-to-line fault due to DC junction box. If the fault is not detected at the time of occurrence then it may leads to fire hazard and hence decreases the overall efficiency of the PV system.

### 3.3 Line-to-ground Fault

A line to ground fault is the most common type of fault occurring in a PV system. Line-to-ground fault results in large current which leads to risk of fire hazards. It occurs due to short circuit between conductor and ground. This type of fault mainly occurs due to 1) insulation failure of cable 2) short circuit between conductor and ground 3) ground fault with PV module.

### 3.4 Other types of fault

In addition to the above mentioned faults there are also some other types of fault such as load mismatch, open circuit fault, optical surface soiling etc. Open circuit faults occurs due to cracked solar cell and solar joint failure, this is due to the mechanical design defect. Under this type of fault instead of supplying the power to the grid it will the power from the grid.

## 4. MATLAB-BASED SIMULATION AND RESULTS

In the figure-3 the array consists of 4 modules. Which are connected in series and parallel connection manner .PV module can be designed either by current input type or

voltage input type model. The PV module parameter is shown in the table 2.

Inputs to PV module	<ul style="list-style-type: none"> <li>PV current <math>I_{pv}</math> [A]</li> <li>Insolation [W/m<sup>2</sup>]</li> </ul>
Outputs	<ul style="list-style-type: none"> <li>PV voltage <math>V_{pv}</math> [V]</li> <li>PV output power <math>P_{pv}</math> [W]</li> </ul>

Table -1 input output model

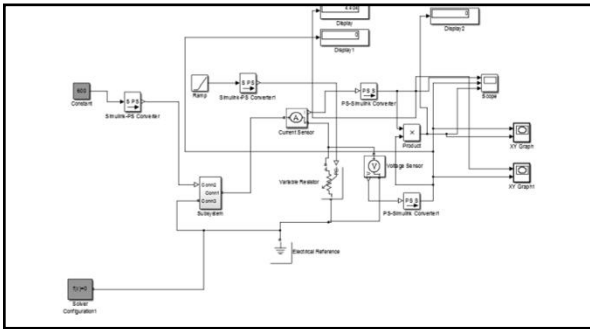

Figure :-3 simulation diagram for solar PV cell

Figure-4 and figure-5 shows the current voltage and power voltage characteristics of PV array with an solar irradiation of 800W/m<sup>2</sup>. The output level changes when the solar irradiation changes

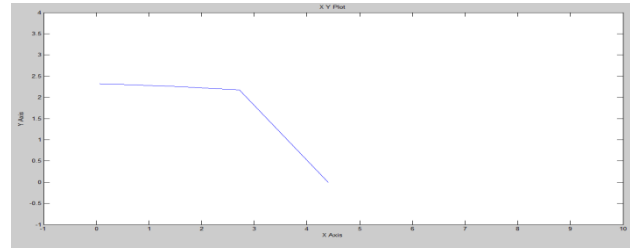

Figure :-4 I-V characteristics of PV array

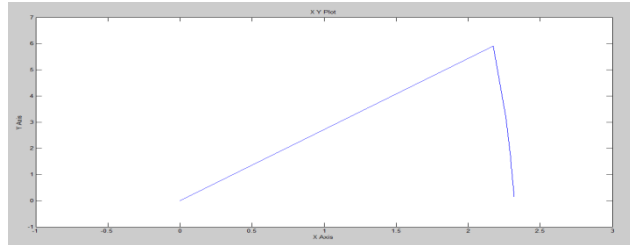

Figure :-5 P-V characteristics of PV array

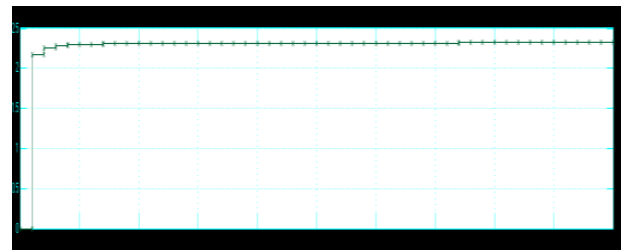

Figure :-6 change in PV array voltage

Figure -6 shows the voltage transition occurring in the system when irradiance level changes.

PARAMETER	VALUE
<b>open-circuit voltage <math>V_{oc}</math> (volts)</b>	10.8
<b>short-circuit current <math>I_{sc}</math> (amps)</b>	5.3
<b>rated current <math>I_R</math> at maximum power point (MPP) (amps)</b>	9.2
<b>pn-junction reverses saturation current (<math>I_0</math>)(amps)</b>	$2.61e^{-1}$
<b>Irradiation to short circuit current gain (G)</b>	0.00482
<b>Cell Parallel Resistance (<math>R_p</math>) (<math>\Omega</math>)</b>	1.343
<b>Cell Series Resistance (<math>R_s</math>) (<math>\Omega</math>)</b>	0.012

Table 2

#### 4.1 Line to ground fault

Under normal operating condition the cells are operating at  $V_{oc}$  and the current is  $I_{sc}$ . The corresponding maximum power is  $M_{pp}$ . Under fault condition the open circuit voltage decreases to  $V_f$  and the corresponding current becomes zero for the faulted string. For other healthy strings the total current becomes  $(n-1)I_{sc}$  which is slightly less than from the healthy condition. This  $(n-1)I_{sc}$  current will also act like a back feeding current hence lies in the forth quadrant of I-V characteristics. So a fuse can be inserted into the circuit so as to protect the solar cell.

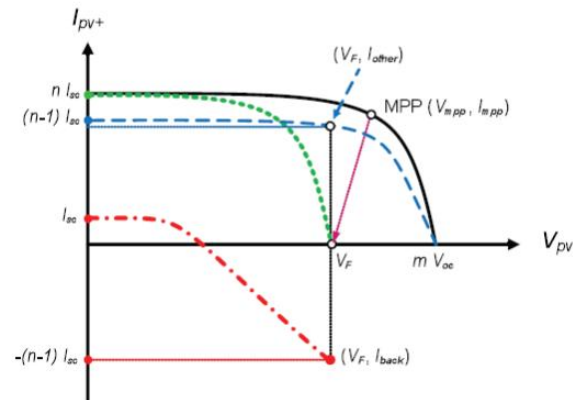

Fig:-7 Characteristic diagram of Line to ground fault

## 4.2 Line to Line fault

A line to line fault is an accidental low resistance connection established between two points of different potential in an electric network.

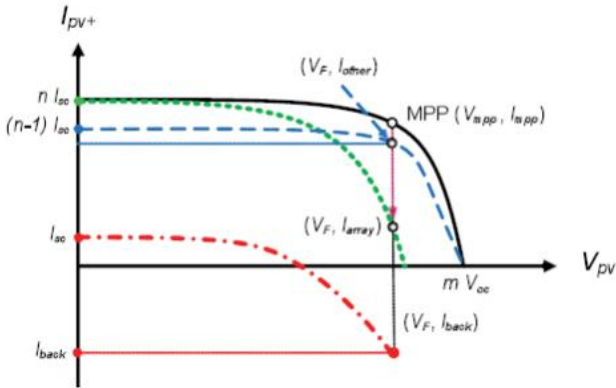

Fig:-8 Characteristic diagram of Line-to-line fault

At the moment of fault, the PV network is working at a voltage of  $V_f$  with  $I_{pv}=0$ , which means the array becomes open circuit and there is no current feeding into PV inverter. Line to line fault reduces the output voltage but a very little dip in the array current. If line to line fault back feeding current exceeds the rated current of over current protection depending on the specific time current characteristics of the fuse, the fault might be cleared and the faulty circuitry will be disconnected.

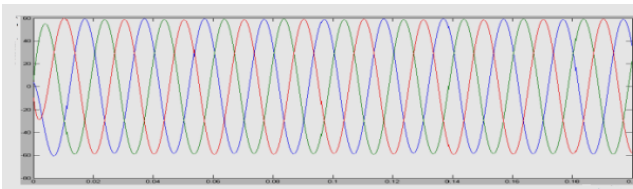

Figure :-9 current wave form under normal operation

Figure -9 and figure-10 shows the current wave form under normal and fault condition occurring in a grid and its effect on the solar PV system. When fault occur the MPPT tries to extract maximum power from the system.

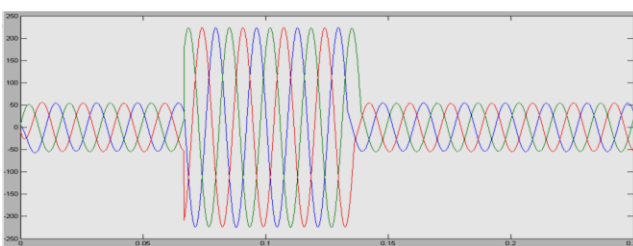

Figure :-10 current wave form under fault condition

## 5. CONCLUSION

We investigated several types of fault occurring in a PV system and their effects to the PV output. The fault control system can be achieved either by current control strategy or by voltage control strategy. Power factor control can be achieved by current control strategies. Under fault condition when high amount of current is generated by the PV system can be prevented from entering into the grid by providing a circuit breaker before the grid.

## REFERENCES

- [1] Mariko Tomisawa, masamitsu tokuda "Suppression of emission radiated from solar cells in photovoltaic power generation system", IEEE symposium on electromagnetic compatibility, pp.1-6, aug.2008.
- [2] Ye zhao, jean-francois de palam, jerry moresian, robert lyons and brad lehman, "Line-line fault analysis and protection challenges in solar photovoltaic arrays", IEEE transaction on industrial electronics, jun.2012, pp.3784-3795
- [3] Ali M.bazzi, katherine A.kim, brian B.johnson, philip T.krein and alejandro Dominguez-garefa, "Fault impacts on solar power unit reliability" twenty sixth annual IEEE applied power electronics conference and exposition, mar.2011, pp.1223-1234.
- [4] Ali M.bazzi, Dominguez-garefa, and philip T.krein, "a method for impact assessment of faults on the performance of the field oriented control drives: a first step to reliability modelling" in IEEE applied power electronics conference and exposition, pp.256-263
- [5] E.L meyer and E.E van dyk, "assessing the reliability and degradation of photovoltaic module performance parameters", IEEE transaction on reliability, vol.53, pp.83-92, 2004
- [6] N.femia, G.P. etrone, G.Spagnuolo, and M.Vitelli, "optimization of perturb and observe maximum power tracking method", IEEE trans.power Electron., vol.20, pp.963-973, 2005
- [7] E.L royal, "investigating the reliability attributes of silicon photovoltaic cell :an over view," IEEE transaction on reliability, vol.R-31, pp.266-269, 1982
- [8] Y.byung-gyu, M. matsui, and Y.gwon-jong, "A correlation-based islanding detection method using current-magnitude disturbance for PV system," IEEE trans.ind.electron., vol.58, pp.2935-2943, 2011
- [9] R.L. steigerwald, A.ferraro, and F.G. turnbull, "application of power transistors to residential and intermediate rating photovoltaic array power conditioners," IEEE trans.ind., vol.IA-19, pp.254-267, 1983
- [10] H.patel and V.agarwal, "maximum power point tracking scheme for PV systems operating under reliability shaded conditions," IEEE trans.ind.electron., vol.55, pp.1689-1698, 2008
- [11] S.K Firth, k.j lomas and s.j rees, "a simple model of PV system performance and its use in fault detection," solar energy, vol.84, pp.624-635, 2010.
- [12] C.L bennet and B.D.russell, "practical high performance fault detection on distribution feeders," IEEE trans.ind.appl., vol.33, pp.635-640, 1997